



## VARTA BLUE dynamic EFB

### Vehicle Key Benefits



Подходящ за базово ниво Старт-Стоп системи



Разработени в съответствие с най-високите стандарти в Германия



Патентована PowerFrame® решетка за надеждна стартова мощност, бързо зареждане и устойчивост на корозия

For more information visit [varta-automotive.com](http://varta-automotive.com)

### ORDER INFORMATION

|                          |               |
|--------------------------|---------------|
| European Type No. (ETN): | 580500080     |
| Article Number:          | 580500080D842 |
| Short Code:              | N80           |
| Barcode:                 | 4016987152324 |
| UK Code:                 | 115EFB        |
| Packaging Unit:          | 1             |
| Quantity per Pallet:     | 42            |

### TECHNICAL INFORMATION

|                        |     |                     |        |
|------------------------|-----|---------------------|--------|
| Voltage [V]:           | 12  | Base Hold-down:     | B13    |
| Battery Capacity [Ah]: | 80  | Layout:             | 0      |
| CCA, EN [A]:           | 800 | Terminal Types:     | 1      |
| Length [mm]:           | 315 | Case Size:          | H7/LN4 |
| Width [mm]:            | 175 | Weight filled (kg): | 21,68  |
| Height [mm]:           | 190 |                     |        |

# DRAWINGS

**B13**

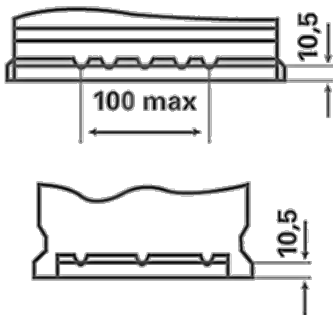

**0**



**1**



**3**

